



HTS

A DIVISION OF **CLASSIC INDUSTRIAL SERVICES**
POWERED BY **API GROUP**

Ω | HTS CONTROL PANELS

MasterTrace Heat Tracing Systems maximizes the performance and reliability of any electrical heat tracing application. Sensing all critical heat trace variables and using the advanced algorithms of its microprocessor. MasterTrace panels provide controllers that warn you of potential problems from a centralized location before they become critical and maintain your heat trace system 24 hours a day, 365 days a year.



SINGLE & DUAL POINT CONTROLLERS

Single and dual point controllers are also available for line and ambient sensing applications in ordinary and hazardous areas. These systems are designed for local control at each heat trace loop, typically for projects with a remote, or fewer circuits required.



Single and dual point controllers are also available for line and ambient sensing applications in ordinary and hazardous areas. These systems are designed for local control at each heat trace loop, typically for projects with remote, or fewer circuits required.

MECHANICAL THERMOSTAT

Mechanical Thermostats are also designed for ordinary and hazardous area use and can be used for local control where information and communication is not critical, but looking for the lowest cost solution.



Ω | HTS SR CABLES

A complete line for the most demanding freeze protection, temperature maintenance and speciality applications in industrial and commercial markets. These products are designed and manufactured to the strictest industry standards and are third-party approved for use in hazardous industrial areas. SR cables available from local distribution centers for quick-ship availability.

- **LXR Heating Cables** are designed for freeze protection and temperature maintenance of metal and plastic pipes. 105°F Maintain, 185°F Exposure, 120-277V operation, (3, 5, 8, 10 w/ft) FM, CSA, UL, CE
- **MXR Heating Cables** are designed for freeze protection and temperature maintenance of metal and tanks. 250°F Maintain, 366°F Exposure, 120-277V operation, (5, 10, 15 w/ft) FM, CSA, CE
- **HXR Heating Cables** are designed for freeze protection and temperature maintenance of metal and tanks. 375°F Maintain, 450°F Exposure, 120-277V operation, (5, 10, 15, 20, 25, 30 w/ft) FM, CSA, CE



Ω | HTS MIx CABLES

Historically, are known as the most durable electric heat trace cables in the world that are designed to be installed on applications with a maximum exposure temperature up to 1100°F. It is the ideal choice when an applications temperature and power output requirements exceed the capabilities of self-regulating and constant wattage cables and need precise temperature control.



Ω | HTS COMPONENTS & ACCESSORIES

They are designed to be the safest and most reliable devices that are required to complete the installation for our complete line of Heat Tracing Cables. The Components meet NEMA 4 requirements and can be installed in temperatures as low as -40°F. The boxes come pre-drilled to accept a 3/4" NPT threaded hub.



Ω | HTS TUBE BUNDLES

Pre-insulated and heat traced tubing is a thermally insulated transport line suitable for steam, gas or liquid transport. The energy-efficient design meets OSHA personnel protection requirements by limiting the jacket surface temperatures to 140°F (60°C). Tube Bundles are used extensively in the power, refinery, and petrochemical industries to connect samples from pipes and vessels, as well as stream tracing to steam supply manifolds. These pre-insulated tube bundles utilize a continuous extruded polymer jacket to prevent moisture egress which is the primary cause of failure compared to field insulated systems which are extremely difficult to seal.



Ω | HTS MODULAR INSTRUMENT ENCLOSURES

Significantly simplifies the installations of rigid enclosures by providing an alignment manifold with pre-set holes for power wiring, control wiring, and process tubes. This allows for a complete installation in the field inclusive of process tubing, electrical, block heaters, calibration and testing without the need of offsite integration and schedule breaks.

Once the manifold is set and is fitted to the pipe stand, the outer shell is then attached via a quick connect design. By reducing installation complexity, our goal is to reduce the "Total Installed Cost" (TIC) per instrument by 30%.

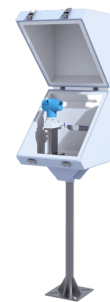

SR CABLES

Ω | HTS offers a complete line of Heat Trace products for the most demanding freeze protection, temperature maintenance, snow melting, de-icing and speciality applications in industrial and commercial markets. These products are designed and manufactured to the strictest industrial and commercial markets. These products are designed and manufactured to the strictest industry standards and are third-party approved for use in hazardous industrial areas. Same-day shipping available on orders placed before noon central time (applies to self-regulating cable, accessories and stock controls only).

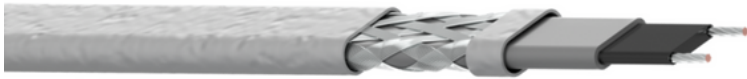

LXR Heating Cables are designed for freeze protection and temperature maintenance of metal and plastic pipes.
105°F Maintain, 185°F Exposure, 120-277V operation, (3,5,8,10 w/ft)
FM, CSA, UL, CE
Cables are available from stock for same-day shipment.



MXR Heating Cables are designed for freeze protection and temperature maintenance of metal pipes and tanks.
250°F Maintain, 366°F Exposure, 120-277V operation, (5, 10, 15 w/ft)
FM, CSA, CE
Cables are available from stock for same-day shipment.



HXR Heating Cables are designed for freeze protection and temperature maintenance of metal pipes and tanks.
375°F Maintain, 450°F Exposure, 120-277V operation, (5, 10, 15, 20, 25, 30 w/ft)
FM, CSA, CE
Cables are available from stock for same-day shipment.

Mix CABLE

Ω | HTS Mineral Insulated (Mix) Cable is known as the most durable electric heat trace cable in the world. It is the ideal choice when an application's temperature and power output requirements exceed the capabilities of self-regulating and constant wattage cables and need precise temperature control. Mix heating cable can be used for applications with the following requirements:

ADVANTAGES OF Ω | HTS Mix CABLES

- Single and dual core series heating resistance cable, magnesium oxide mineral insulated, metal sheath
- High strength
- Heating cable resistance (ohms/m) determines the power output per unit length
- Output power constant, independent of temperature variations
- Maximum working voltage up to 750V
- Output power up to 980W/ft (typical max)
- Highest maintain temperature up to 1472°F
- Maximum exposure temperature up to 1832°F
- Hot and cold end fittings are usually prefabricated

Ω | HTS offers the entire range of heating units to choose from so we can use our experience and expertise to design the most efficient system. This comprehensive range ensures a quick solution to any heating problem.

With this comes total traceability to ensure the highest quality solution. This is vital, as the composition of the cable must be able to withstand a wide range of applications including incredibly harsh conditions. Ω | HTS makes all the connections and seals with advanced technology, which guarantees a consistent high level of quality of the trace heating system. Specific ranges of Mix heating cables and units are approved by various hazardous and corrosive area approvals.

Mix CABLE

CABLE CONFIGURATION

An Mix heat trace cable kit or unit consists of the heating cable, the hot-cold joint and the cold lead cables with an appropriate seal and gland. The connecting and sealing of an Mix heating unit is critical for safe and reliable operation.

The insulation of the inner heating conductor is embedded in magnesium oxide, a non-aging and non-combustible material. A wide range of resistances ensures the termination of a multitude of heating cable lengths with various outputs and nominal voltages. We offer both single core and dual core resistance wires as well as a seamless outer jacket made from Copper, Cupro-nickel, Stainless Steel, Inconel or Alloy 825.

Ω | HTS Mix series heating systems are particularly suitable for heating applications where high power output, high exposure temperatures, or extreme resistance to environment corrosives is needed. Mix heating systems provide the most reliable solutions for temperatures of up to 1832° F.

Mix Cables are suitable for heating of pipes, vessels, flanges and valves and many other applications in both hazardous and non-hazardous area applications.

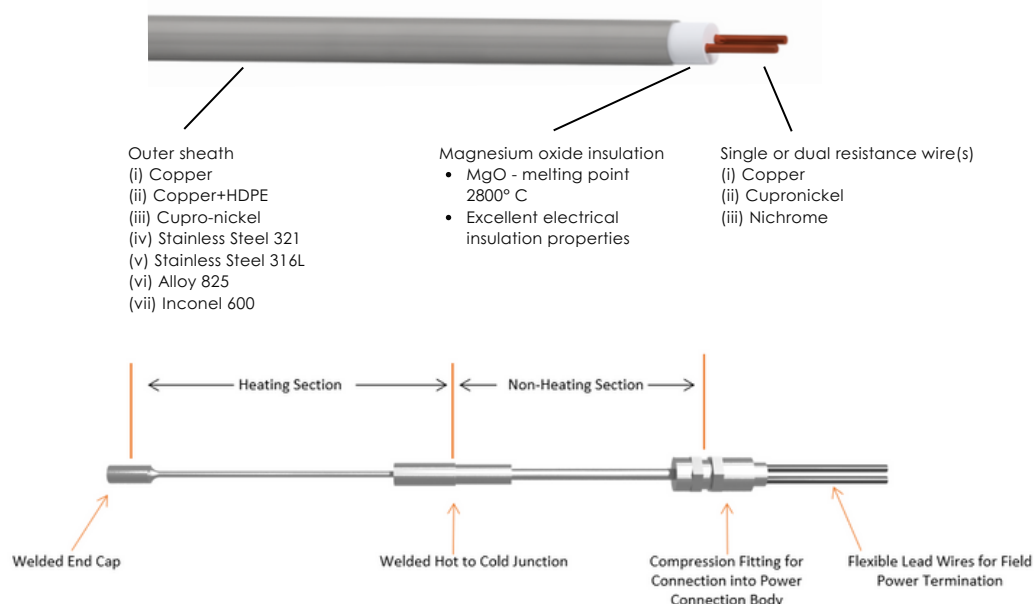

Ω | HTS - Mix Twin Core Range In Alloy 825 and Stainless Steel Description:

Category: "L" - Light duty 300 V rated cable or "H" - Heavy duty 600 V rated two (2) conductor cable with Sheath type "H" - Alloy 825 material or "S" - AISI 321 conductors loop resistance In Ohm/ft resistance with decimal position stated after "-".

For example:

L2H100-2 has resistance: $100 \times 10^{-2} = 1$ Ohm/ft (3.28 Ohm/m)

H2H775-4 has resistance: $775 \times 10^{-4} = 0.0775$ Ohm/ft (0.254 Ohm/m)

TUBING SOLUTIONS

INDUSTRIAL TUBING



Industrial Tube

Application

- Corrosion protection (near she/off shore sites)
- Pneumatic or Hydraulic Control Lines

Tubing Sizes

- 1/4", 3/8", 1/2", 3/4"
- 6mm, 10mm, 12 mm

Common Tube Materials

- 316/316L, Seamless
- #122DHP Copper

Number of Tubes

- 1-7

Max. Operating Temperature

- 140°F/60°C

Options

- Contact Factory

ELECTRIC TRACED TUBING



Self Regulating

Application

- Freeze protection of instrument lines
- Low to medium temperature maintenance
- Viscosity maintenance of oils/grease
- Maintain proper fluid properties in automated equipment
- Hazardous location approvals

Tubing Sizes

- 1/4", 3/8", 1/2", 3/4"
- 6mm, 10mm, 12 mm

Common Tube Materials

- 316/316L, Seamless
- #122DHP Copper
- PFA Fluoropolymer

Number of Tubes

- 1-4

Max. Operating Temperature

- Low temp SR 85°C/185°F
- High temp SR 150°C/302°F

Options

- Carrier tube replaceable heater design
- Multiple heating zones
- Buffered heater cables for high temperature applications to 1100°F/593°C



Power Limiting

Application

- Freeze protection to medium temperature maintenance
- Hazardous location approvals

Tubing Sizes

- 1/4", 3/8", 1/2", 3/4"
- 6mm, 10mm, 12 mm

Common Tube Materials

- 316/316L, Seamless
- #122DHP Copper
- PFA, PTFE, or FEP Fluoropolymer

Number of Tubes

- 1-4

Max. Operating Temperature

- Power limiting 204°C/400°F

Options

- Monel, Incoloy, Hastelloy
- SilcoNert coatings
- Electropolished tubing

STEAM TRACING



Pre-Insulated

Application

- Transport steam from manifold to process vessel
- Return spent steam (condensate) to boiler
- Reduce temperature drop in fluid transfer lines
- Protect personnel from hot tubing

Tubing Sizes

- 1/4", 3/8", 1/2", 3/4"
- 6mm, 10mm, 12 mm

Common Tube Materials

- 316/316L, Seamless or Welded
- #122DHP Copper
- PFA Fluoropolymer

Number of Tubes

- 1

Max. Operating Temperature

- 400°F/204°C
- 1100°F/593°C

Options

- Stack, Grab & Go 100 ft boxes
- High temperature designs to 1100°F



Light Steam Traced Application

Application

- Protect freezing in instrument lines
- Prevent degradation of process fluid
- Maintain temperature of heated fluids, prevent boil-off

Tubing Sizes

- 1/4", 3/8", 1/2", 3/4"
- 6mm, 10mm, 12 mm

Common Tube Materials

- 316/316L, Seamless or Welded
- #122DHP Copper
- PFA Fluoropolymer

Number of Tubes

- 2-4

Max. Operating Temperature

- 400°F/240°C
- 1100°F/593°C

Options

- Other materials and aftermarket options available (contact factory)



Heavy Steam Traced Application

Application

- Temperature maintenance
- Viscosity maintenance
- Transfer of heavy waxes or oils

Tubing Sizes

- 1/4", 3/8", 1/2", 3/4"
- 6mm, 10mm, 12 mm

Common Tube Materials

- 316/316L, Seamless or Welded
- #122DHP Copper

Number of Tubes

- 2-7

Options

- Other materials and aftermarket options available (contact factory)

TUBING SOLUTIONS

CEMS



High Temp

Application

- Nox/SOx

Max. Operating Temperature

- High temp SR 150°C/302°F

Options

- Special conditioning of fluoropolymer tubing for low THC applications
- Electropolished stainless steel tubing



Power Limiting Application

Application

- Ammonia
- CO, CO₂, O₂

Tubing Sizes

- 1/4", 3/8", 1/2", 3/4"
- 6mm, 10mm, 12 mm

Common Tube Materials

- PFA Fluoropolymer
- PFTA Fluoropolymer

Number of Tubes

- 1-8

Max. Operating Temperature

- Power limiting 204°C/400°F

Options

- SilcoNert coatings
- Multiple heat zones



Series Resistance

Application

- HCl
- Total hydrocarbons
- Scrubber monitoring
- Mercury
- Particulate monitoring
- Mercury
- Particulate monitoring
- Flare Gas
- LNG
- Petrochemical process monitoring

Common Tube Materials

- 316/316L, Seamless or Welded

Number of Tubes

- 2-4

Max Operating Temperatures

- 400°F/204°C
- 1100°F/593°C

Options

- Monel, Incoloy, Hastelloy
- SilcoNert coatings
- Electropolished tubing



Probe Support

Application

- Temperature maintenance
- Viscosity maintenance
- Transfer of heavy waxes or oils

Tubing Sizes

- 1/16", 1/8", 1/4", 3/8", 1/2"
- 4mm, 6mm, 10 mm, 12 mm

Common Tube Materials

- PFA Fluoropolymer
- PTFE Fluoropolymer
- 316/316L, seamless or welded
- HDPE
- Nylon

Number of Tubes

- 1-12 (includes wires & cables)

Max Operating Temperatures

- 60°C/140°F

Options

- Calibration gas
- Blowback air
- Vacuum lines
- Sensor cables
- Probe power
- Fiberoptic cables
- Cat6 cables

PRODUCT ACCESSORIES



Seal-Tite End Boots

- Seal-tite End Boots seal out moisture and fumes, providing weather resistant, water tight protection for terminating tube bundles, transitions, breakouts and splices.
- Seal-Tite End Boots also protect mechanical parts against corrosion and abrasion.
- Heat-shrinkable and easy to install, Seal-Tite End Boots are made from a thermally stabilized, modified polyolefin, and are available in one to four leg configurations.



UniSeal Cable Entry Seals

- UniSeals are designed to form a water and fume-tight seal at the juncture of tube bundles/cables and panel houses, connection boxes or other enclosures.
- The three-piece seal includes a rigid plastic nut, a silicone O-ring, and an internally threaded nose. The threaded nose is made of rigid and impact resistant material while the seal is made of heat shrinkable, modified polyolefin materials.
- UniSeals are designed for bundle entrances into thin walled enclosures up to 3/16" thickness. Seals are designed to work in two areas: at the enclosure (with an O-ring) and at the bundle sheath (with the heat shrinkable nose end).

INSTRUMENT ENCLOSURES

RETROFIT ENCLOSURE SPECIFICATIONS

Outer Dimensions H x W x L:	23.58" x 18.75" x 23.61"
Inner Dimensions H x W x L:	59.89cm x 47.62cm x 59.96cm
	21.95" x 17.92" x 23.08"
	55.75cm x 45.51cm x 58.62cm
Material Thickness:	1/4" (0.635cm)
Material Type:	ASA Plastic w/ glass reinforcement
Protection Standard:	IP 65 (NEMA 4X)
Gasket Material:	Neoprene gaskets
Color:	Light grey
Approx. Weight:	15.8 lbs (7.167 Kg)
Pipe Stand Mount Size:	sch 40 2" pipe dia (2.375")
	sch 40 5.08cm pipe dia (6.03cm)
Lip Support:	(1) Stainless steel lid support
Hinges:	(2) Stainless steel hinges
Latches:	(2) Stainless steel latches
Hardware:	All Stainless steel hardware

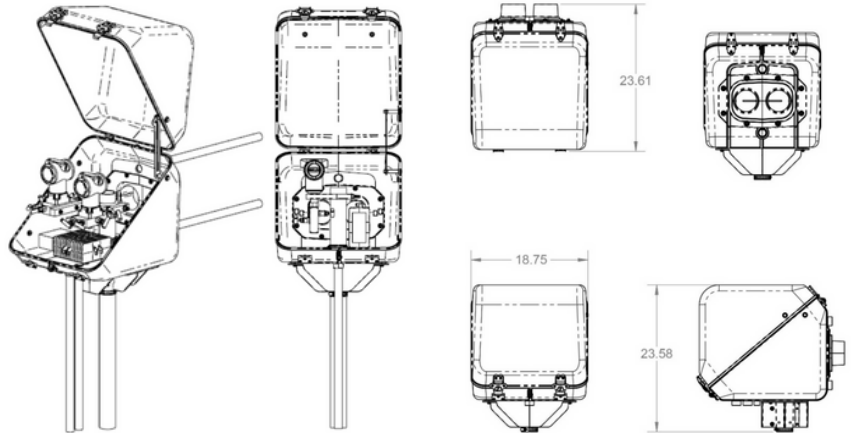

RETROFIT ENCLOSURE PARTS LIST

ITEM NO.	Part	QTY.
1	FAS001 Enclosure Housing Top Rev A	12
2	FAS001 Enclosure Housing Bottom Right Rev A	12
3	FAS001 Enclosure Housing Bottom Right Rev A	12
4	FAS001 Enclosure Housing Bottom Left Rev A	12
5	FAS001 Enclosure Housing Bottom Left Rev A	12
6	FAS001 Enclosure Housing Flange Square Rev A	2
7	FAS001 Enclosure Post Bracket Rev A	2
8	FAS001 Enclosure Housing Flange Nut Rev 1	4
9	FAS001 Enclosure Housing Flange Nut Small Rev 1	1
10	FAS001 Enclosure Housing Insulation Top	1
11	FAS001 Enclosure Housing Insulation Bottom Right	1
12	FAS001 Enclosure Housing Insulation Bottom Left	1
13	FAS001 Enclosure Lid Support	1
14	Hinge McMaster 11175A140 Top	2
15	Hinge McMaster 11175A140 Bottom	2
16	Latch McMaster 1406A720 Top	24
17	Latch McMaster 1406A720 Bottom	24
18	5415K21_Worm-Drive Clamps for Firm Hose and Tube	1
19	93365A154 10-32 x .225 Insert	36
20	93365A160 .25-20 x .3 Insert Brass	22
21	92196A537 .25-20 x .5 SHCS 18-8	22
22	92141A029 .25 Washer 18-8	16
23	91772A826 10-32 x .312 PHP 18-8	14
24	91771A847 10-32 x .43 FHP 18-8	12
25	92198A552 .25-20 x 2.5 Hex Bolt PT 18-8	2
26	91845A029 .25-20 Nut 18-8	2
27	91831A029 .25-20 LockNut 18-8	2
28	92825A137 .25 x 1.5 Spacer Polyethylene	2
29	9452K368 8.75 O-Ring	1
30	9452K171_OIL-RESISTANT BUNA-N MULTIPURPOSE O-RING	2
31	FAS001 Instruments	1

