

INSTALLATION INSTRUCTIONS

These installation instructions are for use with HTS Self-Regulating heater products: For use with LXR and MXR Families of Heating Cables.

The Power Connection Kit is designed for use in ordinary and Division 2 locations. This kit provides excellent resistance to UV rays from sun, as well as Inorganic chemicals and most corrosives.

For technical support call HTS.

PARTS LIST

Description	Quantity
Base	1
Top	1
Sealing Grommet (large hole)	1
Sealing Grommet (small hole)	1
Sealing Gasket	1
Shrink Tubes 1/8" x 5 1/2" (black)	2
Shrink Tube 1/4" x 5 1/2" (green/yellow)	1
Shrink Tube 1/2" x 1 1/2" (white)	1
Lock Ring	1
Adapter (for installation on pipe smaller than 1")	1
Stainless Steel Tie Wire	1

INSTALLATION FOR HEATER WITH BRAID AND OVER JACKET

(Note: Use grommet with larger hole for heater with braid and over jacket.)

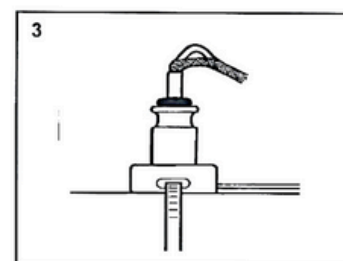
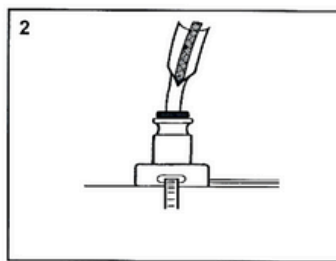
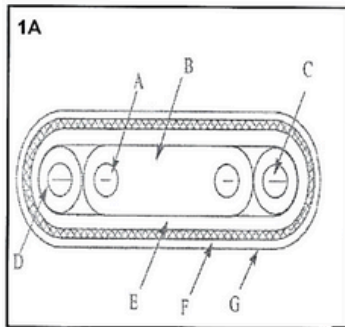
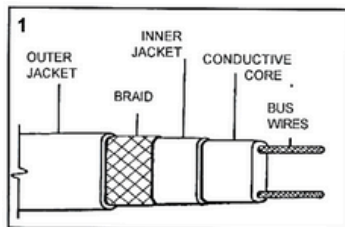

Extend the heater 7 1/2" above the base. Slide the grommet over the heater inserting the grommet in the base. Strip outer jacket 7" from end. Attach the base to the pipe with a pipe strap. (See Heat Trace Stripping Instructions for details.)

Make an opening in the ground braid, bend the heater, and pull the inner jacket and core through the opening in the braid. Twist the ground braid into a pigtail.

Self-Regulating Heating cable w/Dual Monitor Wires
For cables with monitor wires connect each monitor wire to the power source. The opposite end will connect to the monitor light and/or other monitoring devices.

PARTS LIST

Description	Quantity
Base	1
Top	1
Sealing Grommet (large hole)	1
Sealing Grommet (small hole)	1
Sealing Gasket	1
Shrink Tubes 1/8" x 5 1/2" (black)	2
Shrink Tube 1/4" x 5 1/2" (green/yellow)	1
Shrink Tube 1/2" x 1 1/2" (white)	1
Lock Ring	1
Adapter (for installation on pipe smaller than 1")	1
Stainless Steel Tie Wire	1

INSTALLATION FOR HEATER WITH BRAID AND OVERJACKET

(Note: Use grommet with larger hole for heater with braid and overjacket.)

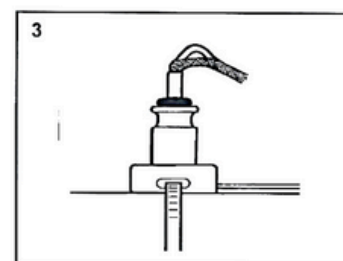
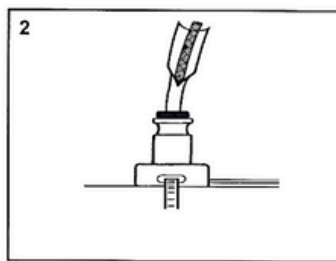
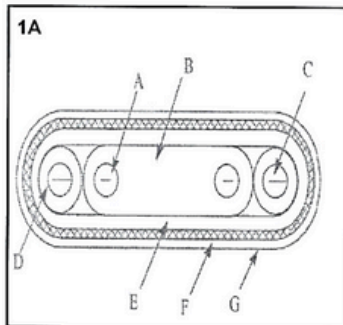
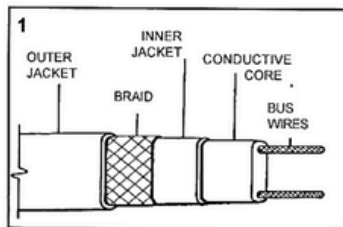

Extend the heater 7 1/2" above the base. Slide the grommet over the heater inserting the grommet in the base. Strip outer jacket 7" from end. Attach the base to the pipe with a pipe strap. (See Heat Trace Stripping Instructions for details.)

Make an opening in the ground braid, bend the heater, and pull the inner jacket and core through the opening in the braid. Twist the ground braid into a pigtail.

Self-Regulating Heating cable w/Dual Monitor Wires
 For cables with monitor wires connect each monitor wire to the power source. The opposite end will connect to the monitor light and/or other monitoring devices.

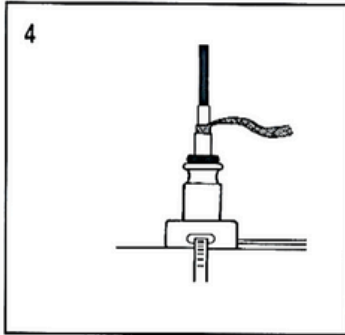

4 Strip the inner jacket 6" from the end. Strip the bus wires out of the core, following the Heat Trace Stripping Instructions.

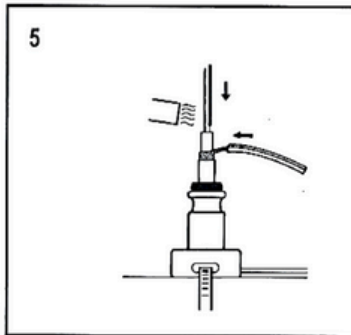

5 Slide the black 1/8" x 5 1/2" heat-shrink tubes on the bus wires, and the green/yellow 1/4" x 5 1/2" heat-shrink tube on the ground pigtail. Heat shrink, using a heat gun, or soft flame torch, moving the heat source back and forth.

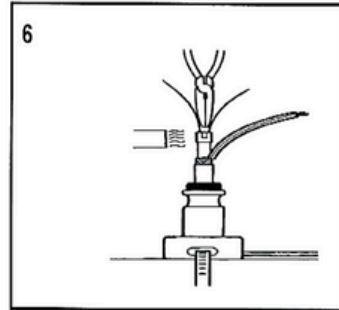

6 Slide the white 1/2" x 1 1/2" heat-shrink tube in place over the bus wires and onto the inner jacket. Heat shrink in place. After removing the heat source, and while still hot, pinch the center of the heat-shrink tube between the bus wires with needle-nose pliers.

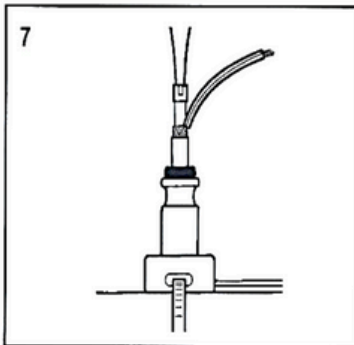

7 Make sure the sealing grommet is set in the base.

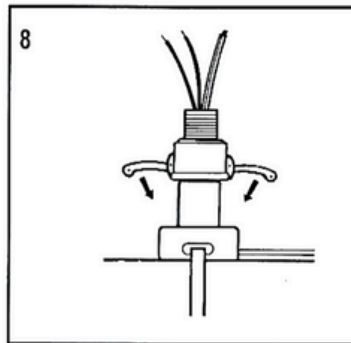

8 Slide the top in place and push and lock the cam levers into position. Lock cam levers by inserting the stainless steel tie wire through the holes in the ends of the cam levers and twisting together.

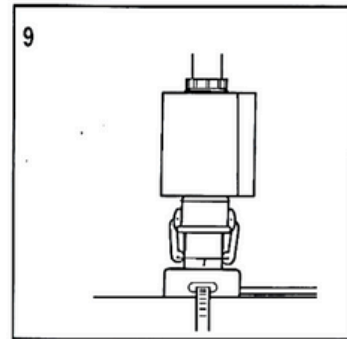

9 Mount junction box with non-threaded opening for 3/4" conduit, using the sealing gasket and lock ring to hold in place, or use a junction box with a 3/4" inside threaded hub.

INSTALLATION FOR HEATER WITH BRAIDS ONLY

(Note: Use grommet with smaller hole for heater with braid only and no overjacket.)

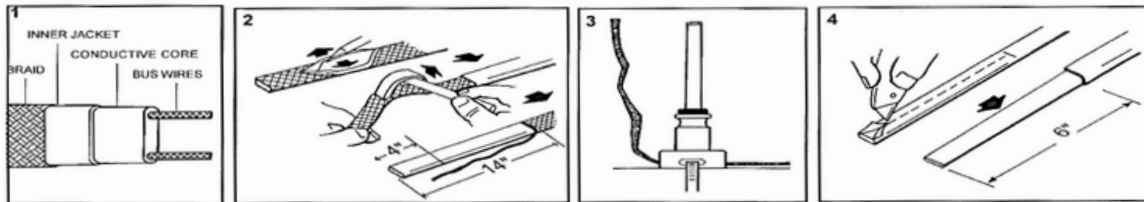

1 Make an opening in the braid 14" from the end. Bend the heater and pull it through the opening. Twist the braid into a pigtail. Cut 4" of heater off end of the heater.

3 Extend the heater 7 1/2" above the base. Allow braid pigtail to extend out from bottom of base. Attach base to pipe with a pipe strap. Slide the grommet over the heater and push into cavity in base.

4 Strip the jacket 6" from the end to expose the conductive core.

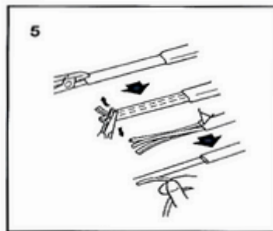

5 Notch the center core between the conductors and pull the bus wires away from the core for 6". Remove the center core material and any core material on the bus wires. Retwist the bus wires, if needed.

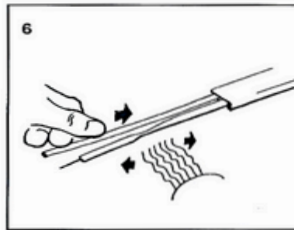

6 Slide the 1/4" x 5/16" heat-shrink tubes on the bus wires. Shrink the tubes with heat gun or soft flame torch.

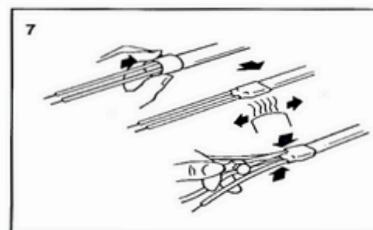

7 Slide the 1/2" x 1/16" heat-shrink tube over the bus wires and partially over the inner jacket. Heat shrink the tube; while still hot, pinch the center of the heat-shrink tube between the bus wires with needle-nose pliers.

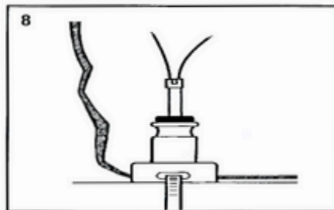

8 Make sure the sealing grommet is set in the base.

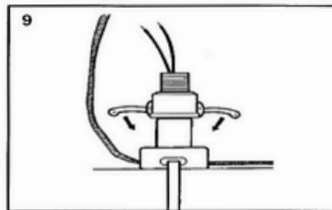

9 Slide the top in place and push and lock the cam levers into position. Lock cam levers in place by inserting the stainless steel tie wire through the holes in the ends of the cam levers and twisting together.

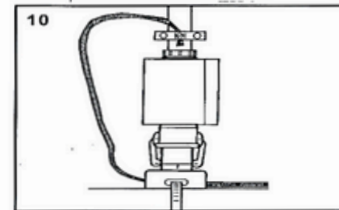

10 Mount junction box with non-threaded opening for 3/4" conduit, using the sealing gasket and lock ring to hold in place, or use a junction box with a 3/4" inside threaded hub. Ground the braid pigtail to conduit with a clamp (not provided).