

INSTALLATION INSTRUCTIONS

- use with LXR Series Heaters.



CONNECTION KIT 1548-40000

SPX-40 electrical connection kit is a universal all-in-one connection kit for making the electrical connections for LXR Series self-regulating heating elements. The kit contains the necessary components (except conduit box) to make one input connection or one splice connection or one input power splice connection as well as two termination connections. The connection kit fits pipe up to 6" IPS. For larger pipes, use additional cable ties end-to-end (PN 01D2-43018; not included). The SPX-40 kits are Factory Mutual approved for use in Class I, Division 2, Group B, C, and D; Class II, Division 2; Class III, Division 2 areas.

STRIPPING PROCEDURE

1. Remove the outer jacket approximately 1" from the end of the heater, exposing the core.
2. Cut out the web of core material 1" wide x 3/4" long.
3. Strip conductive core 1/4" from the end of each bus wire, using wire strippers.

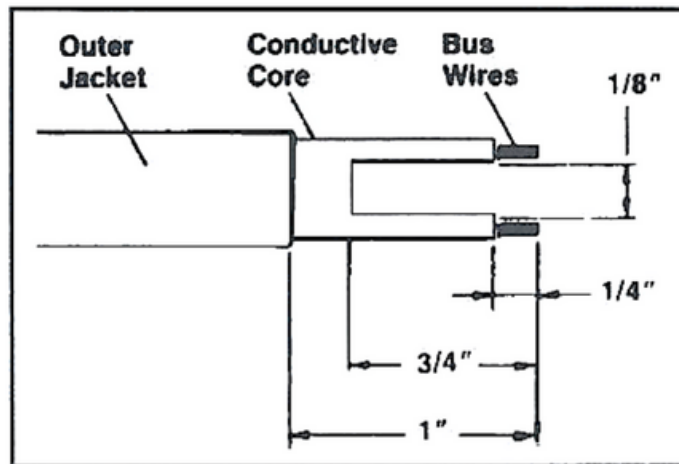

BRAIDED HEATER GROUNDING FOR CLASS 1, DIVISION 2 AREAS

1. Remove 10" of metallic braid from the end of the heating element.
2. Unravel the next 2" of metallic braid and twist into a pigtail. Attach the ring tongue connector to the pigtail.
3. Connect the ring tongue connector to the connection nipple using a ground screw.

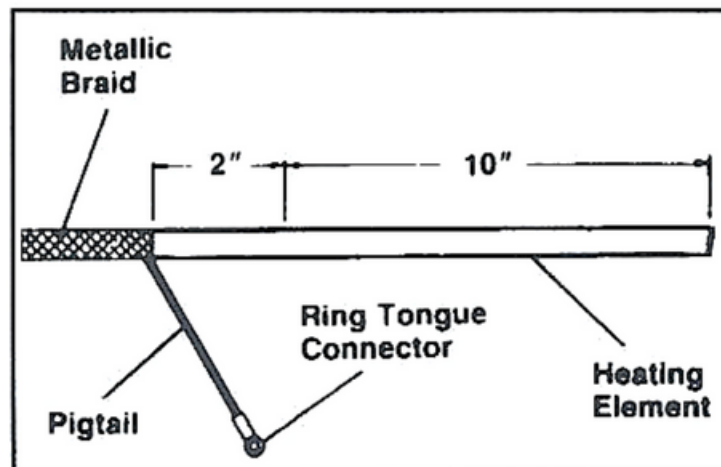

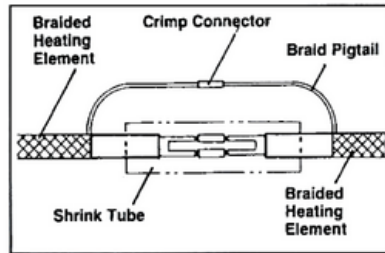

SPLICE CONNECTION PROCEDURE

1. Bring the heating elements together allowing approximately 1/4" gap between them.
 - 1A. For braided heater — unravel braid 4" from end of each heater and twist braid into pigtail. Trim the pigtail to remove the tapered end.
2. Separate the heater conductors following the stripping procedure.
3. Slide the shrink tube over one of the heating element ends.
4. Connect the heaters together using the small insulated crimp connectors.
5. Cover the entire splice area with end sealant. Slide the shrink tube over the splice so it is centered over the crimp connection and shrink into place.
 - 5A. When splicing braided heater, braid must not be covered by the shrink sleeve.
 - 5B. Connect the two braid pigtails formed in 1A using a large insulated crimp terminal.
6. Secure the spliced area to the pipe with high-temperature tape.

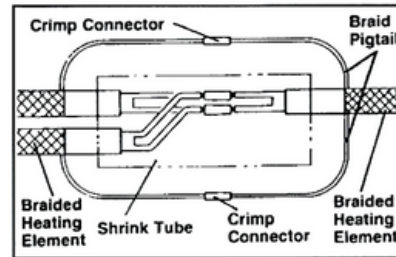

TEE SPLICE CONNECTION PROCEDURE

1. Follow steps 1 and 2 in splicing instructions.
 - 1A. For braided heater unravel the braid 4" from the end of each heater.
2. For the tee connection, twist together one bus wire from the end of each heater.
3. Slide the shrink tube over the single heater.
4. Connect the three heaters using the large insulated crimp connectors.
5. Seal the splice area with the end sealant. Seal the ends of the heaters and any part where the jacket has been removed.
6. Center the shrink tube over the splice and shrink into place.
 - 6A. If braided heater is used, braid must not be covered by shrink tube.
 - 6B. Separate the braid on the single heater into two equal strands. Twist the braid to form two pigtails on the single heater and one pigtail each on the other heaters.
 - 6C. Connect the braid pigtails as shown in the diagram, using two large insulated crimp connectors.

1. Remove the metallic braid 3" from end.
2. Trim end of the heating elements so that one bus wire is 1/4" shorter than the other.
3. Slide the termination shrink cap over the end of the heater and shrink into place.
4. Anchor the heating element and end cap onto the pipe using high-temperature tape.

